

Document ID: 4846406

Mobile Telephone Cradle Package Installation

[Installation Instructions Part Number](#)

84158294

Kit Contents

Qty	Description
1	Module
1	Module Bracket
1	Rubber Mat
3	Screws
1	Push Nut
1	Installation Instructions

Procedure

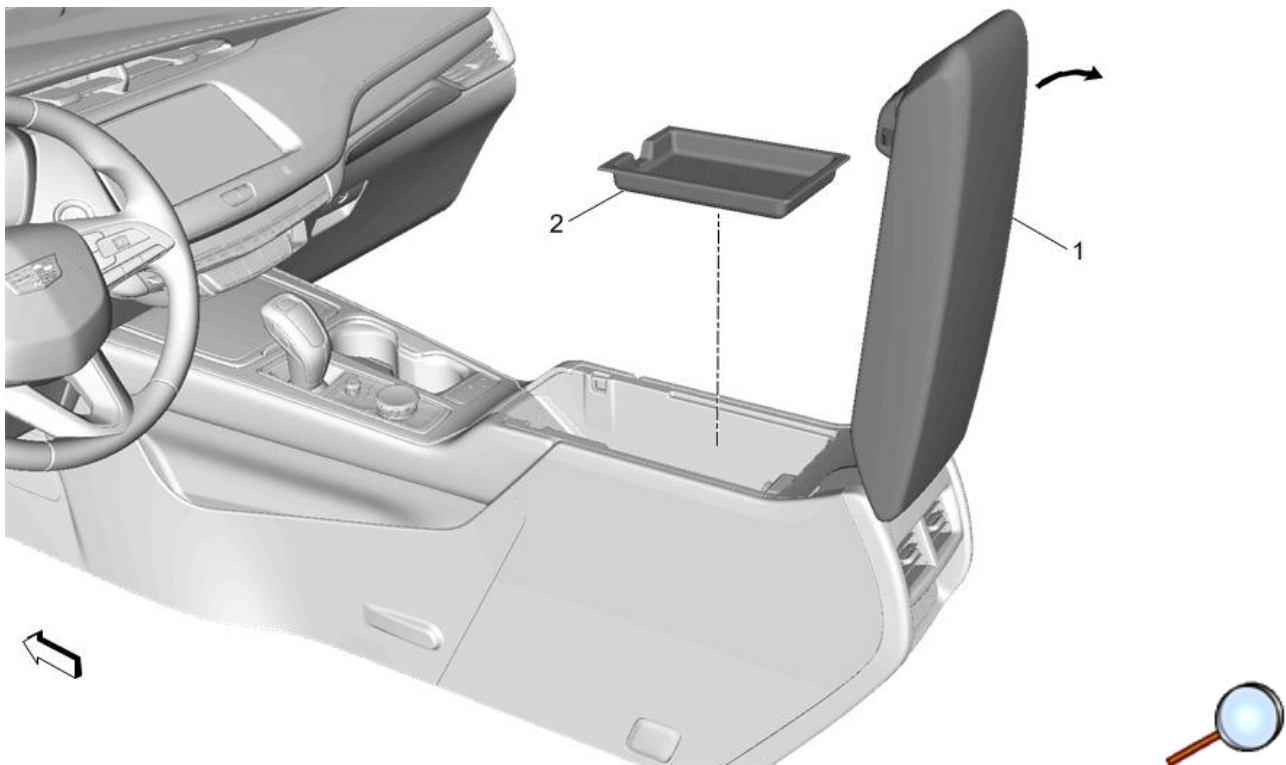

1. Lift and rotate the console armrest (1) to the open position.
2. Lift out and remove console bin storage tray (2).

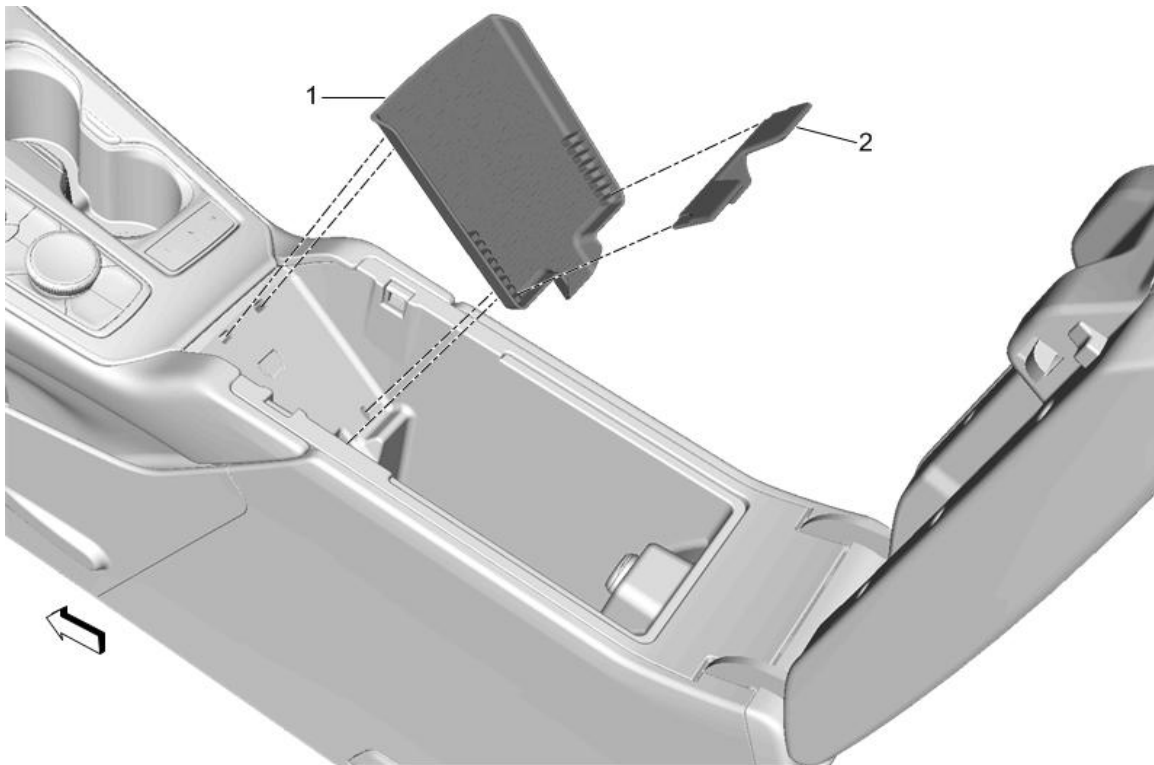

3. Using a suitable tool remove and discard the front floor console liner mat (1).

Note: Do not reinstall the front floor console liner mat as it will cause interference with charging.

4. Remove and retain the console liner divider (2) from the console liner. This will be reused later in procedure.

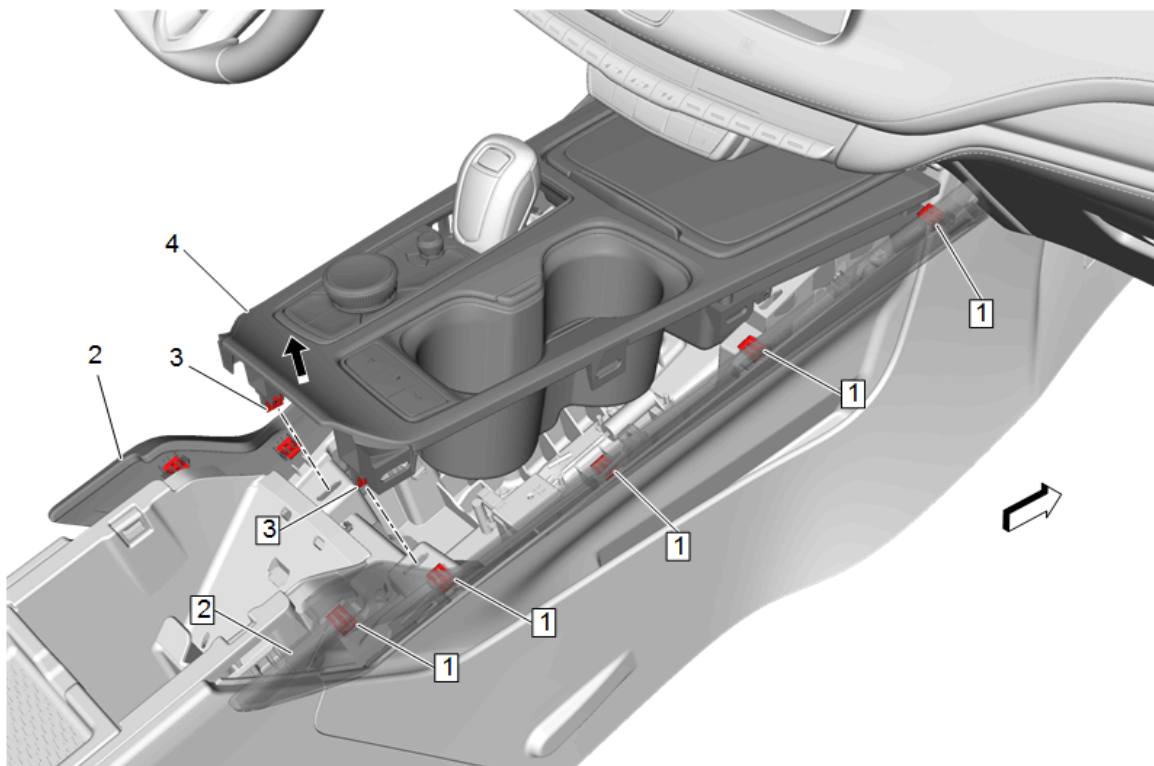

5. Using a flat-bladed plastic trim tool, disengage the upper retainers (1) on the left and right front floor console applique panels (2).

6. Using a flat-bladed plastic trim tool, lift up and disengage the rear retainers (3) on the rear of console trim plate (4) to allow access to remove bin.

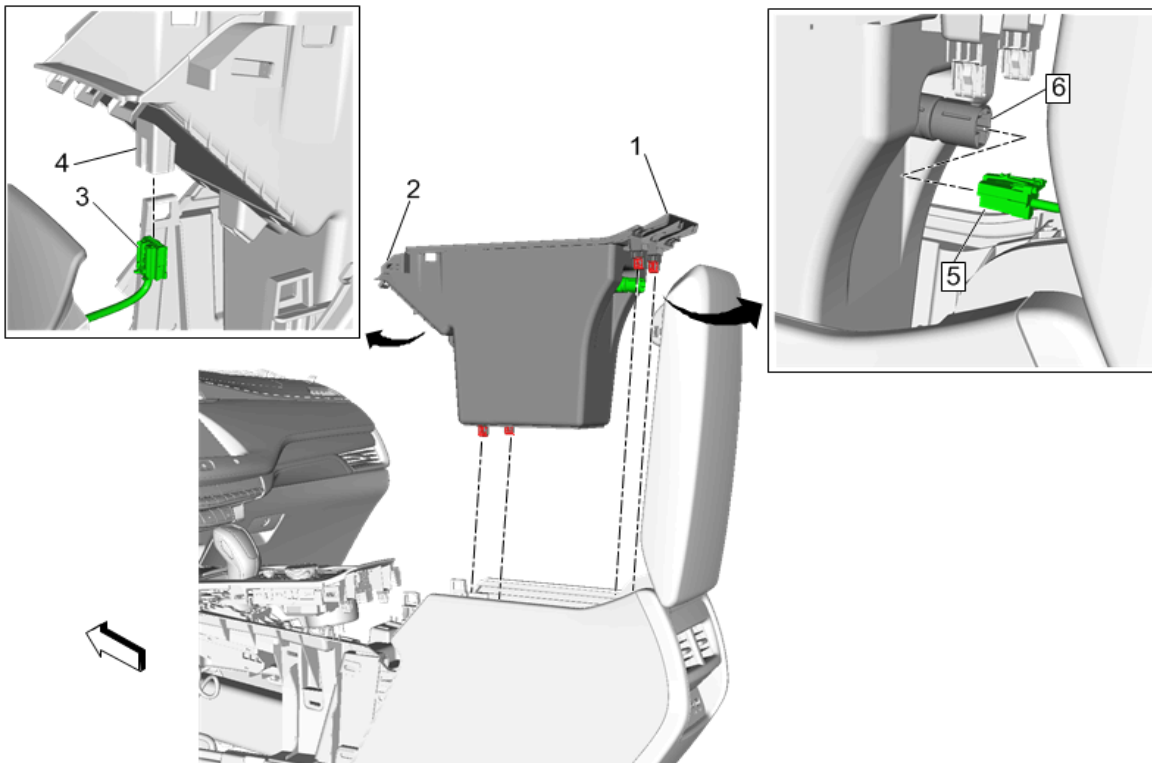

7. Using a flat-bladed plastic trim tool, first carefully pry up the rear of bin (1), then pry up the front of bin (2) to disengage the retainers.
8. Grasp the rear and front of bin and begin to lift out. Once bin is slightly lifted, disconnect the connector (5) from accessory power outlet (6).
9. At the front of console bin locate the charger connector (3) and disconnect from underside of bin (4), remove bin from console.

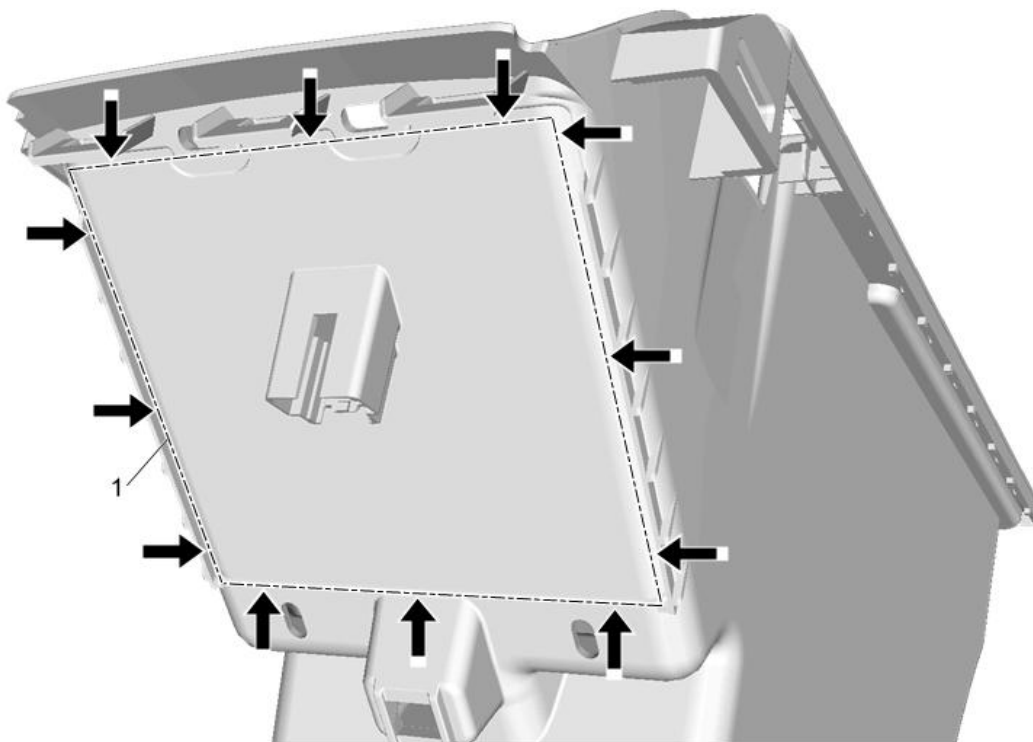

10. Place bin on work bench.
11. Locate the groove line (1) on the bin base as shown.

12. Using an appropriate cutting tool, cut out the area noted according to the groove. This will be needed to install the wireless charger in place just beneath the bin. Once cut is complete discard the cut portion.

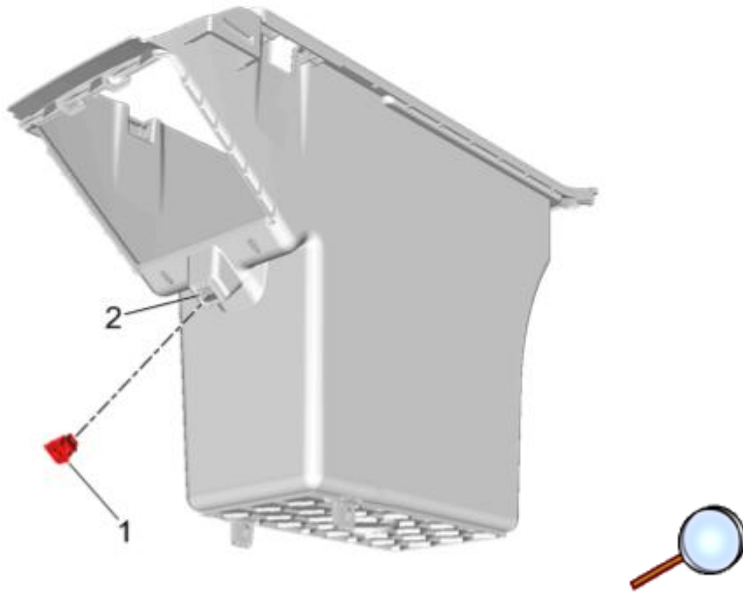

Caution: Use the correct fastener in the correct location. Replacement fasteners must be the correct part number for that application. Fasteners requiring replacement or fasteners requiring the use of thread locking compound or sealant are identified in the service procedure. Do not use paints, lubricants, or corrosion inhibitors on fasteners or fastener joint surfaces unless specified. These coatings affect fastener torque and joint clamping force and may damage the fastener. Use the correct tightening sequence and specifications when installing fasteners in order to avoid damage to parts and systems.

13. Install supplied push nut (1) into the underside of bin slot (2).

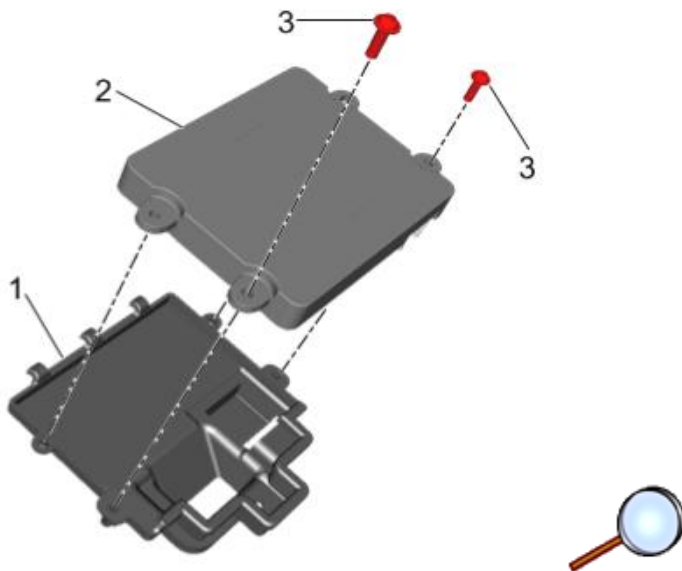

14. Assemble bracket (1) in the kit to wireless module (2) using two screws (3) supplied in kit. Tighten screws to 1.0 N.m (11 lb in).

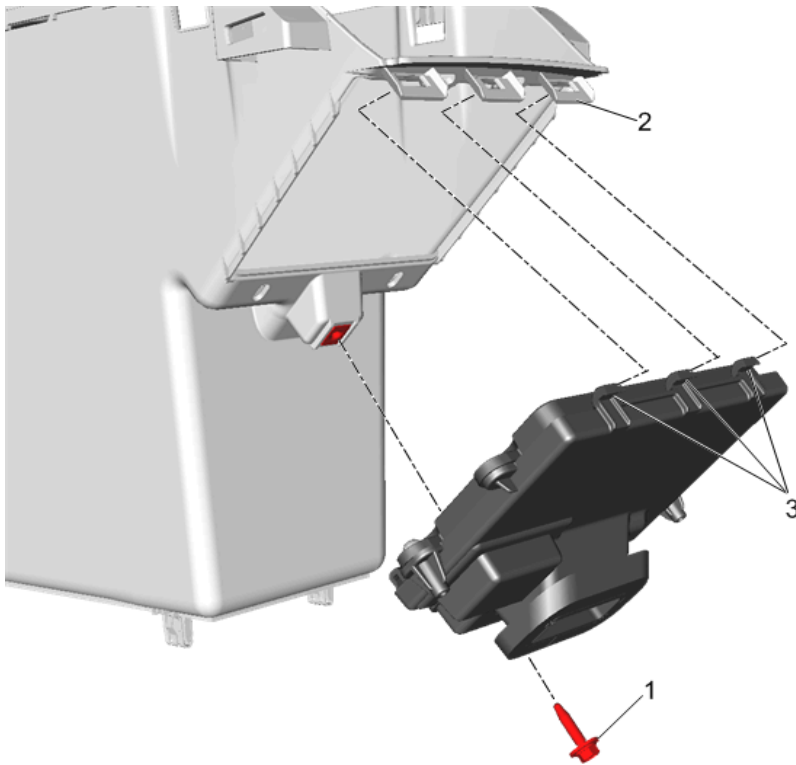

15. Hook bracket (3) into slots of lower side of bin (2). Swing into place and secure with supplied screw (1). Tighten screw to 2.5 N.m (22 lb in).

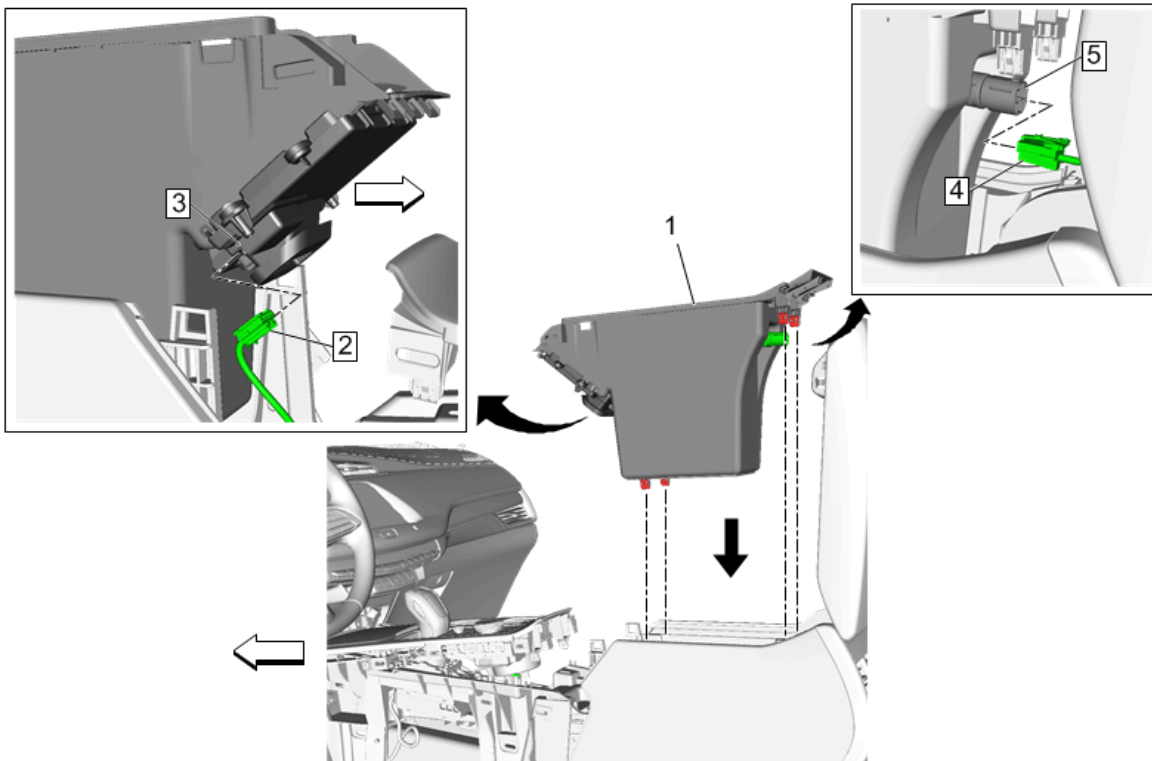

16. Carefully position bin (1) back into console. Before bin is fully installed, connect electrical connector (2) to wireless charger and connector (4) to accessory power outlet (5).

17. Position bin into place and engage retainers.

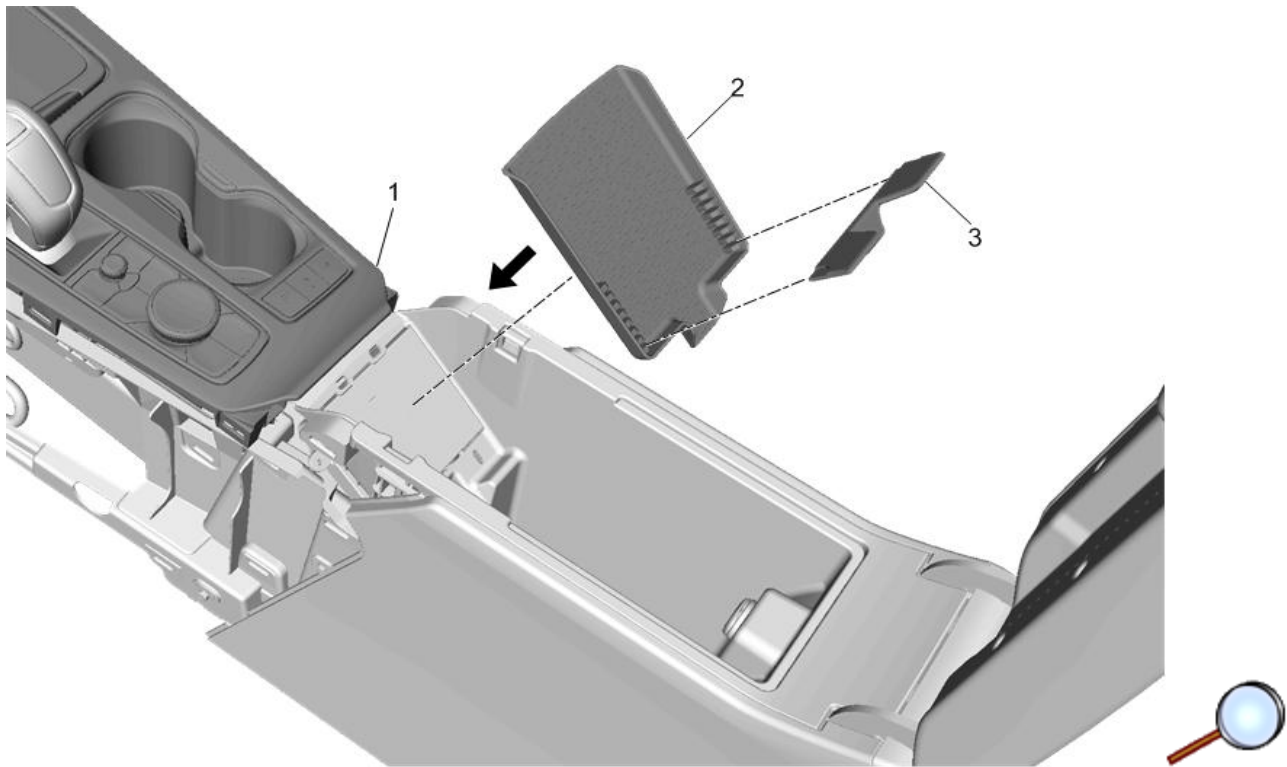

18. Refasten console trim plate (1) engaging the retainers.
19. Install new wireless charger liner (2) to the bin using the snap features.
20. Install the previously retained divider (3) to the new liner.

Calibrations and Final Steps

1. With the support of the Tech Line, download the new BCM calibration to support the new Wireless Charging feature.

Note: The installation of this accessory Wireless Charger kit requires programming and configuring of the vehicle. This is done with a Service Programming System (SPS-TIS2WEB). Call TCSC to obtain a VCI number. United States 1-888-337-1010 Canada (English) 1-800-828-6860 Canada (French) 1-800-503-3222. The Techline Customer Support Center will provide programming instructions and changes to the vehicles calibration settings. You must provide the vehicle identification number (VIN) of the vehicle to be programmed and the authorization code when calling TCSC.

2. Using the Scan Tool with a MDI, and (SPS-TIS2WEB), update the body control module (BCM) calibration to activate the charging system and indicator telltale.
3. Test the function of the charger to determine if the telltale illuminates with a chargeable phone in place:
 - Start the vehicle
 - Use a phone that is compatible with Wireless Charging (PMA or Qi)
 - Place the phone face up on the liner and move it slowly until the charging icon is displayed on the infotainment screen
4. Reinstall all previously removed components (except as noted) and reconnect any formerly disconnected electrical connections.